

TwinCut

for Internal thread turning

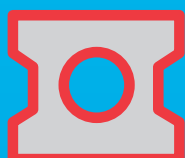

Edition 2012-11



**Scandinavian
Tool Systems**

Scandinavian Tool Systems AB is a Swedish based manufacturer and supplier of tools for thread turning, thread milling, parting off and grooving.

The main product is the QuadCut[®], which on the North American market is sold under the name QuadThread[®].

Our products are sold through distributors in more than 30 countries worldwide.

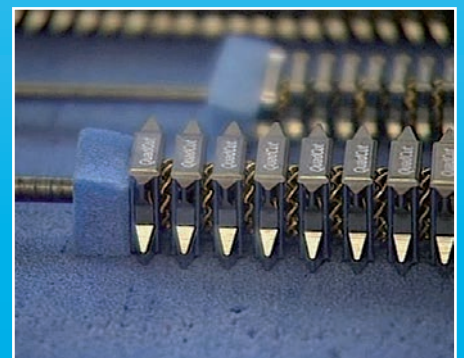
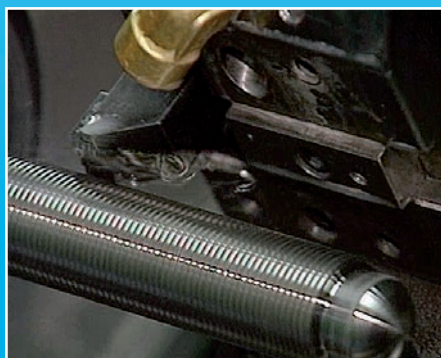
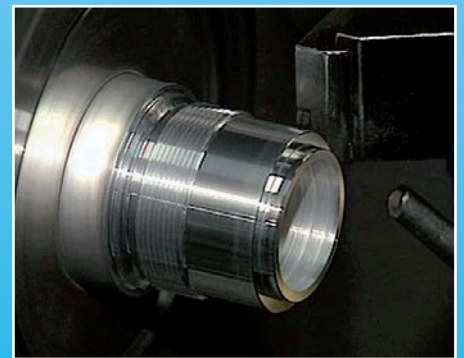
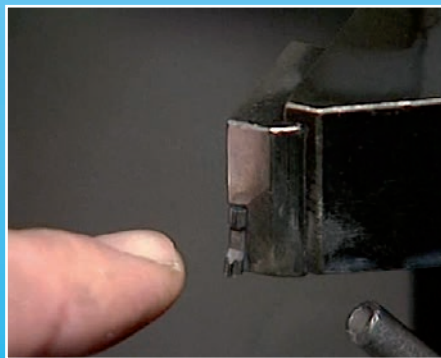
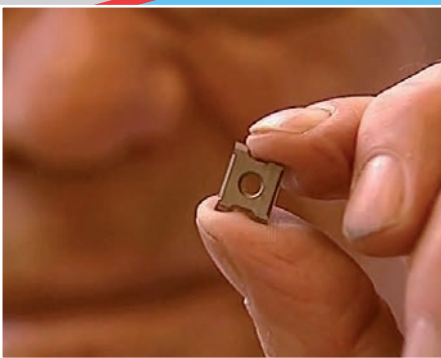

General information about the TwinCut system	4
---	----------

TwinCut inserts

Partial Profile.....	5
ISO Metric (M)	5
ISO Unified (UN).....	6
Whitworth (BSW, BSP).....	6
Trapezoidal DIN 103.....	6
Round DIN 405.....	7
ACME	7
STUB ACME	7
NPT	8
NPTF Dryseal	8

TwinCut toolholders

Small toolholders	9
Cassette-type toolholders	9
Internal cassettes	10
Screws, Keys	10

• = Stock standard
* = Limited stock

TwinCut

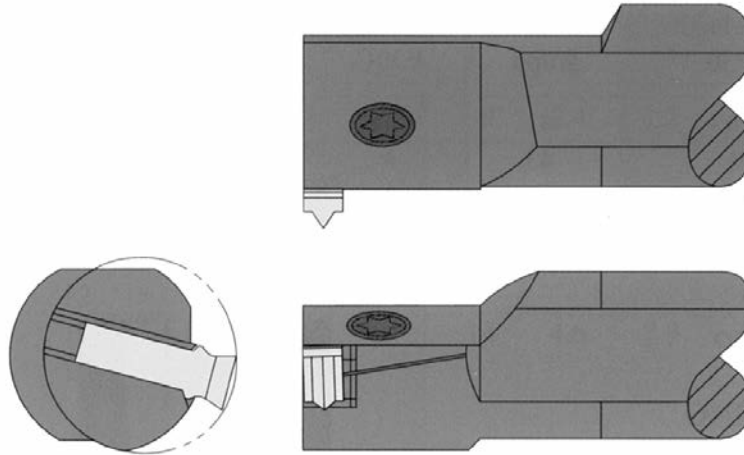

The TwinCut system is suited for applications where larger pitches is required but where the hole diameter is limited. The TwinCut system allows internal threading in holes with a diameter from .71" mm and above. The TwinCut insert has two cutting edges, with a chipbreaker sintered into it.

Since the system has very high indexing accuracy, the cutting edge can be changed without time-consuming dimensional resetting.

TwinCut inserts can be used for both right-hand and lefthand threads, which cuts down your stock-keeping needs.

The larger toolholders have replaceable cassettes for different insert sizes, which drastically reduces the toolholder costs.

Technical information

CUTTING DATA

The table gives recommended cutting speeds in feet/min. for different materials and carbide grades.

Material	P30C
Low-carbon steel $\leq 650\text{N/mm}^2$	590-720
Carbon steel 650-850N/mm ²	430-620
Alloyed tool steel and heat-resistant steel	400-530
Stainless steel	330-560
Cast iron HB 180-250	
Non-ferrous materials	

NUMBER OF PASSES

The table gives only general recommendations. Many times fewer passes can be used, depending on material and setup.

Pitch mm	3.5	4.0	4.5	5.0	5.5	6.0
Pitch TPI	7	6	5.5	5	4.5	4
Nr. of passes	11-18	11-18	11-19	12-20	12-20	12-20

The above recommendations are for full profile UN, ISO and Withworth. For Trapezoidal, ACME, NPT please contact your local STS distributor.

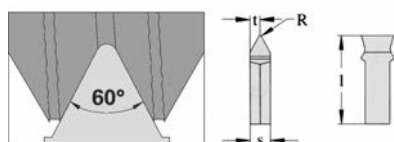

Partial Profile 60°

Internal threading

Pitch		Catalog number	Dimensions				Stock standard P30C	Price-group
mm	TPI		l	s	t	R		
0.5-3.0	48-8	14N AG60	.551	.181	.091	.003	•	848
2.5-4.0	11-6	14N GN60	.551	.181	.091	.007	*	848
4.5-6.0	5-4	18N NV60	.709	.268	.134	.013	*	849

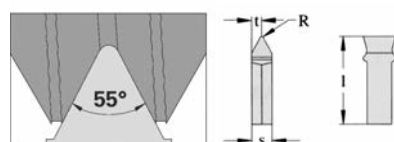

Partial Profile 55°

Internal threading

Pitch		Catalog number	Dimensions				Stock standard P30C	Price-group
mm	TPI		l	s	t	R		
0.5-3.0	48-8	14N AG55	.551	.181	.091	.003	*	848
2.5-4.0	11-6	14N GN55	.551	.181	.091	.012	*	848
4.5-6.0	5-4	18N NV55	.709	.268	.134	.026	*	849

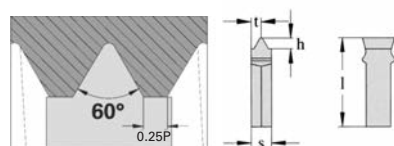

ISO Metric (M)

Internal threading

Pitch mm	Catalog number	Dimensions				Stock standard P30C	Price-group
		l	s	t	h		
3.5	14N 3.5ISO	.551	.181	.091	.081	*	848
4.0	14N 4.0ISO	.551	.181	.091	.092	*	848
4.5	18N 4.5ISO	.709	.268	.134	.104	*	849
5.0	18N 5.0ISO	.709	.268	.134	.115	*	849
5.5	18N 5.5ISO	.709	.268	.134	.127	*	849
6.0	18N 6.0ISO	.709	.268	.134	.138	*	849

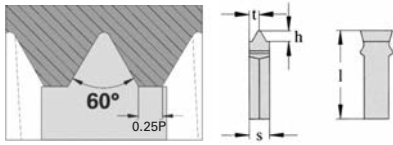

ISO Unified (UN)

Internal threading

Pitch TPI	Catalog number	Dimensions				Stock standard P30C	Price- group
		l	s	t	h		
7	14N 7UN	.551	.181	.091	.083	*	848
6	14N 6UN	.551	.181	.091	.098	*	848
5	18N 5UN	.709	.268	.134	.117	*	849
4.5	18N 4.5UN	.709	.268	.134	.130	*	849
4	18N 4UN	.709	.268	.134	.146	*	849

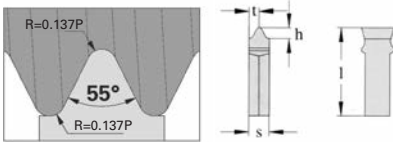

Whitworth (BSW, BSP)

Internal threading

Pitch TPI	Catalog number	Dimensions				Stock standard P30C	Price- group
		l	s	t	h		
7	14N 7W	.551	.181	.091	.093	*	848
6	14N 6W	.551	.181	.091	.108	*	848
5	18N 5W	.709	.268	.134	.130	*	849
4.5	18N 4.5W	.709	.268	.134	.144	*	849
4	18N 4W	.709	.268	.134	.162	*	849

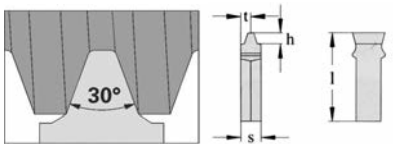

Trapezoidal DIN 103

Internal threading

Pitch mm	Catalog number	Dimensions				Stock standard P30C	Price- group
		l	s	t	h		
4.0	14N 4.0TR	.551	.181	.091	.089	*	849
5.0	18N 5.0TR	.709	.268	.134	.108	*	849
6.0	18N 6.0TR	.709	.268	.134	.138	*	850

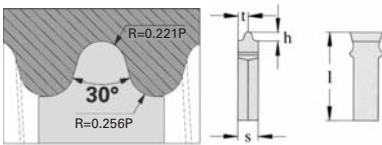

Round DIN 405

Internal threading

Pitch TPI	Catalog number		Dimensions				Stock standard P30C	Price- group
			l	s	t	h		
6	14N	6RD	.551	.181	.091	.083	*	849
4	18N	4RD	.709	.268	.134	.125	*	850

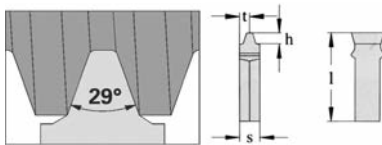

ACME

Internal threading

Pitch TPI	Catalog number		Dimensions				Stock standard P30C	Price- group
			l	s	t	h		
6	14N	6ACME	.551	.181	.091	.100	*	849
5	18N	5ACME	.709	.268	.134	.118	*	850
4	18N	4ACME	.709	.268	.134	.143	*	850

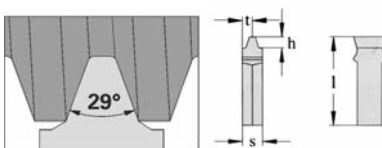

STUB ACME

Internal threading

Pitch TPI	Catalog number		Dimensions				Stock standard P30C	Price- group
			l	s	t	h		
6	14N	6STACME	.551	.181	.091	.067	*	849
5	18N	5STACME	.709	.268	.134	.078	*	850
4	18N	4STACME	.709	.268	.134	.093	*	850

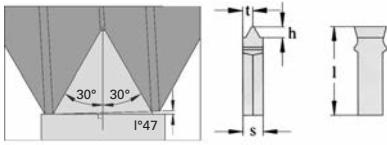

NPT

Internal threading

Pitch TPI	Catalog number		Dimensions				Stock standard P30C	Price- group
			l	s	t	h		
8	14N	8NPT	.551	.181	.091	.095	*	849

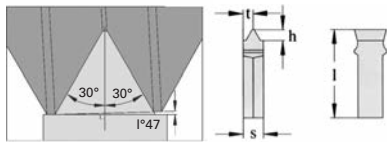

NPTF Dryseal

Internal threading

Pitch TPI	Catalog number		Dimensions				Stock standard P30C	Price- group
			l	s	t	h		
8	14N	8NPTF	.551	.181	.091	.095	*	849

WARNING! Always check if you need NPT or NPTF thread profiles, before selecting the insert.

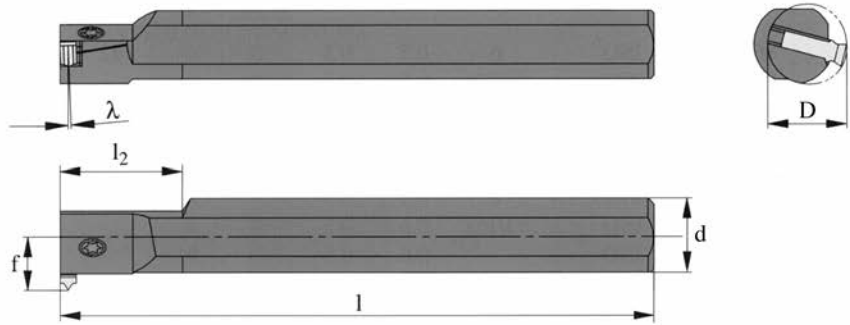
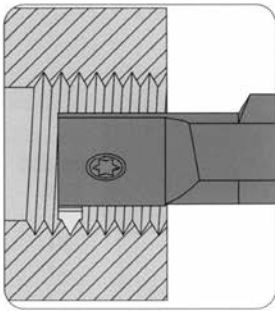

Small toolholders

Catalog number	Dimensions					Insert	Stock standard (λ)						Price-group
	D	l	l ₂	f	d ₂		4.5	3	1.5	0	98.5	97	
QNR 0625 5-14	.625	5.0	1.25	.433	.664	14N	*	*	*	*	*	*	862
QNR 075 6-14	.75	6.0	-	.493	.905	14N	*	*	*	*	*	*	862
QNL 0625 5-14	.625	5.0	1.25	.433	.664	14N	*	*	*	*	*	*	862
QNL 075 6-14	.75	6.0	-	.493	.905	14N	*	*	*	*	*	*	862

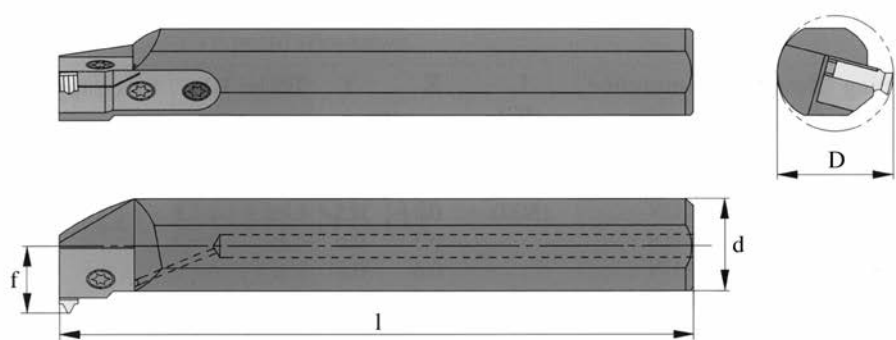
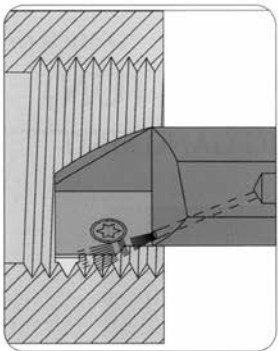

Cassette-type toolholders

Catalog number	Dimensions				Cassettes		Stock standard	Price-group
	D	l	f	d ₂	Insert 14N	Insert 18N		
QNR 100 7-C25	1.00	7.0	.657	1.157	QNR 25-14	QNR 25-18	•	862
QNR 125 8-C25	1.25	8.0	.782	1.407	QNR 25-14	QNR 25-18	•	863
QNR 150 10-C25	1.50	10.0	.907	1.657	QNR 25-14	QNR 25-18	•	864
QNL 100 7-C25	1.00	7.0	.657	1.157	QNL 25-14	QNL 25-18	•	862
QNL 125 8-C25	1.25	8.0	.782	1.407	QNL 25-14	QNL 25-18	•	863
QNL 150 10-C25	1.50	10.0	.907	1.657	QNL 25-14	QNL 25-18	•	864

Toolholders delivered without cassette, to be ordered separately.

f-Dimension

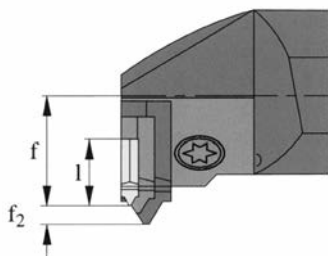

For cassette-type toolholders, the f-dimension is displaced dependent upon the insert size according to the f₂-dimension in the table.

Dimensions	
l	f ₂
.354	0
.551	.039
.709	.098

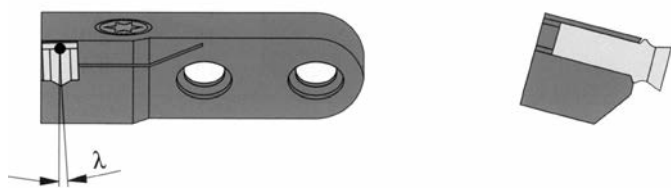

Internal cassettes

Catalog number	Insert	Stock standard (λ)						Price-group
		4.5	3	1.5	0	98.5	97	
QNR 25-14	14N		*	*	*	*	*	861
QNR 25-18	18N	*	*	*	*	*	*	861
QNL 25-14	14N		*	*	*	*	*	861
QNL 25-18	18N	*	*	*	*	*	*	861

Screws

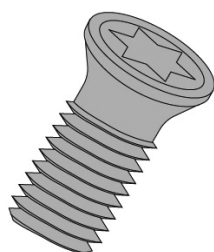

Catalog number	Used for	Price-group
STST15xM5	Insert 14N	221
STST15xM5	Insert 18N	221
STST15xM5	Cassettes	221

Keys

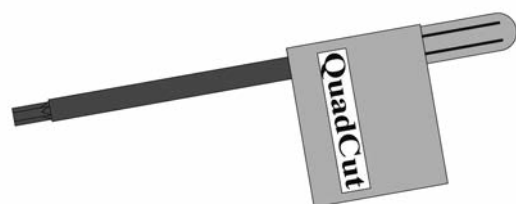

Catalog number	Used for	Price-group
Torx T15	STST15xM5	222

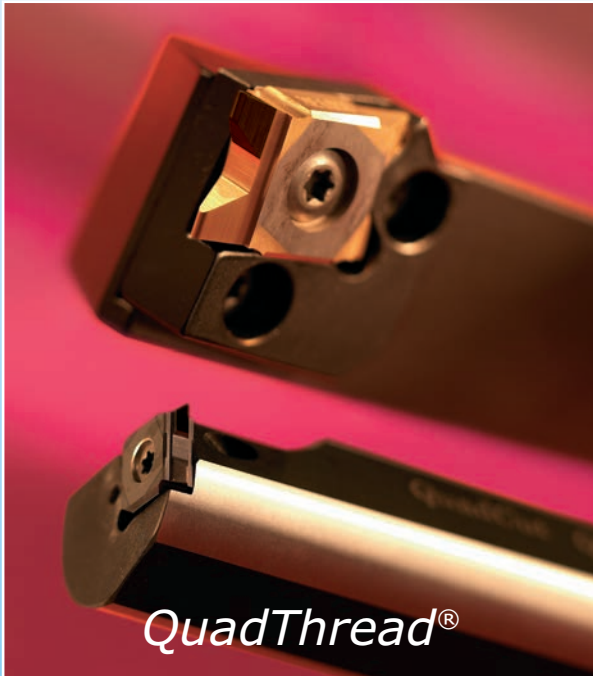

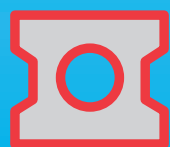

***Scandinavian
Tool Systems***

Scandinavian Tool Systems Inc.

640 Lakeview Plaza Blvd. • Suite C • Worthington, OH 43085

Phone +1 614-231-3051 • Fax +1 614-436-4898 • sales@scandinaviantoolsystems.com

www.scandinaviantoolsystems.com